

Cavity Back Spiral Antenna

2-6GHz

This model is ideally suited for amplitude matching and phase or gain tracking. It is particularly designed for EMC surveillance, direction finding, telemetry, reflector feed and system integration, among other applications.

Throughout its performance, it shows an excellent impedance match and radiation pattern control over the broad operation bands.

Its lightweight and compact design matches its endurance and reliability in harsh and extreme environmental conditions.

This antenna has Left Hand Circular Polarization (LHCP) and is also available in Right Hand Circular Polarization (RHCP).

- Low VSWR
- Left Hand Circular Polarization (LHCP) or Right Hand Circular Polarization (RHCP)
- Excellent impedance match and radiation pattern control
- N-type or SMA Female Connector

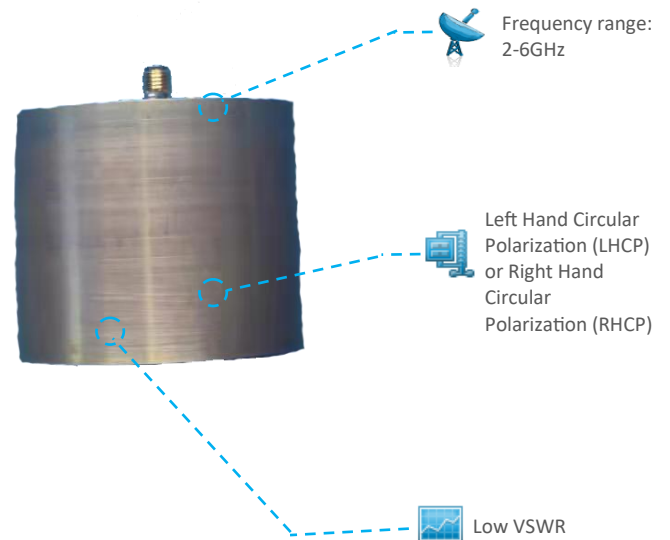

RF Parameters

Frequency Range (GHz)	2-6GHz		
Gain	-4 ~5 dBi		
Polarization	Left Hand Circular Polarization (LHCP) or Right Hand Circular Polarization (RHCP)		
Axial Ratio	≤3		
3dB Beamwidth	Min	50°	
	Max	120°	
VSWR	Typ.	<2.5	
Input Type	Coaxial	Impedance (Ω)	50
Operation Temperature	-55°C ~ +75°C	Size	Φ65mm×40.5mm (excluded connector)
Storage Temperature	-65°C ~ +85°C	Material	Aluminium
Input Connector	N-type or SMA Female	Location	Indoor

Note 1: The specification provided is at nominal bias voltage and at 25°C unless otherwise specified.

Note 2: The specification is subject to regular reviews and will be updated from time to time as part of our continuing product development and improved spec accuracy.

Note 3: Operation beyond the quoted limits stated above may cause instantaneous and permanent damage.



Outline Drawing:
All dimensions are in mm

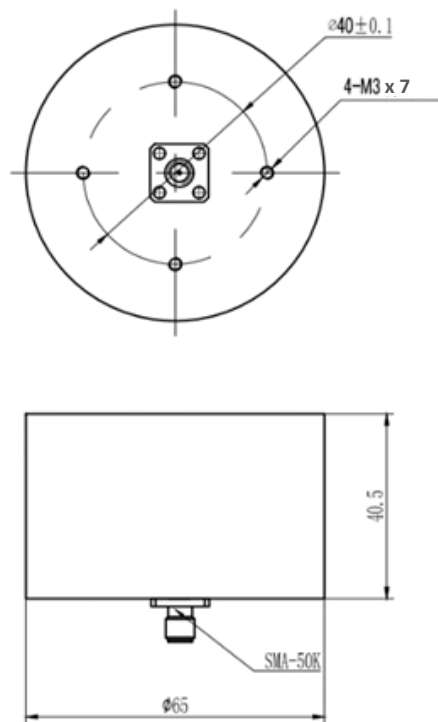

Typical RF Performance

Gain

Frequency (GHz)	Max Gain (dB)
2	-2.9
2.5	-1.8
3	-0.2
3.5	0.7
4	1.1
4.5	1.9
5	2.3
5.5	2.9
6	3.6

Note 1: The specification provided is at nominal bias voltage and at 25°C unless otherwise specified.

Note 2: The specification is subject to regular reviews and will be updated from time to time as part of our continuing product development and improved spec accuracy.

Note 3: Operation beyond the quoted limits stated above may cause instantaneous and permanent damage.

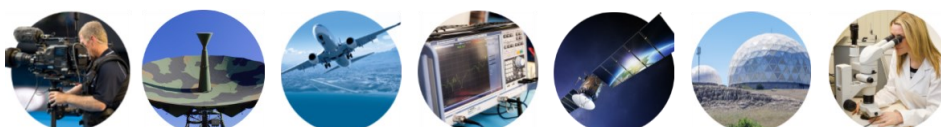

Beamwidth

Frequency (GHz)	E-Plane 3dB Beamwidth	H-Plane 3dB Beamwidth
2	91°	81°
2.5	80°	80°
3	79°	78°
3.5	81°	73°
4	83°	77°
4.5	89°	75°
5	100°	81°
5.5	95°	78°
6	77°	68°

Pattern

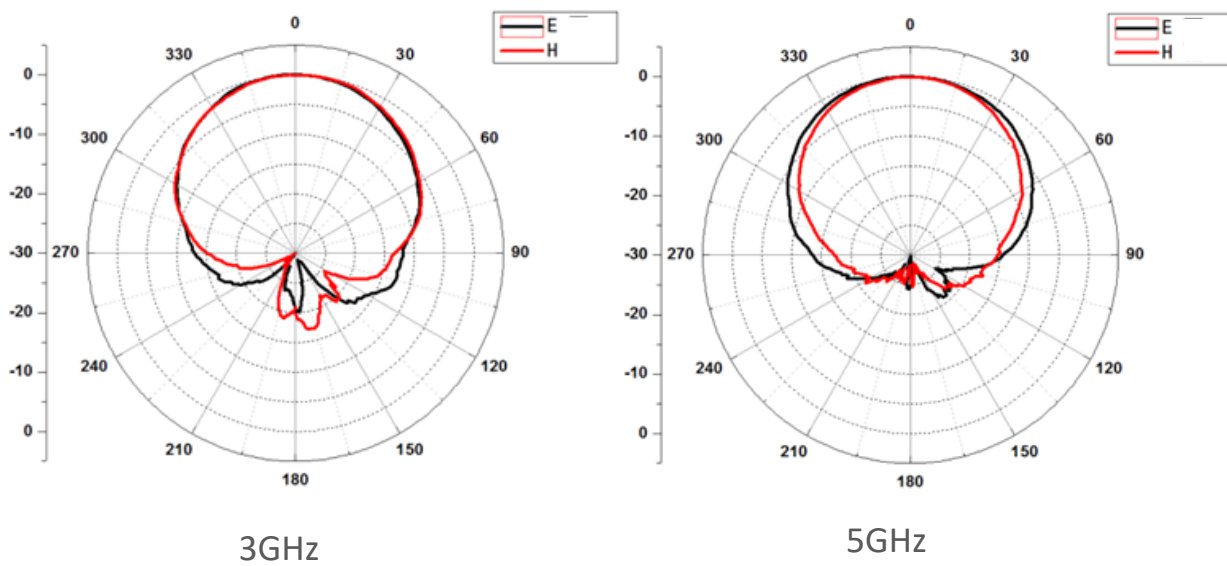

Note 1: The specification provided is at nominal bias voltage and at 25°C unless otherwise specified.

Note 2: The specification is subject to regular reviews and will be updated from time to time as part of our continuing product development and improved spec accuracy.

Note 3: Operation beyond the quoted limits stated above may cause instantaneous and permanent damage.

